

Installation Instructions for the

8 & 15 Amp AC SAW Command & Railsounds
4.0 Conversion Board

Directions prepared by

TASTudios
4137 Boardman-Canfield Rd
Suite LL02
Canfield, OH 44406
(330) 533-7181 TEL
(330) 533-7208 FAX

www.tastudios.com

Contents

Introduction	2
Upgrade kit contents	3
Installation format	3
Diesel installation	3
Installing the program/run switch	4
Fuel tank speaker mounting	5
Mounting the SAW board	5
Wiring the program/run switch & the speaker	5
Installing the antenna	6
Wiring the motors and pickup wires	6
Wiring directional lighting	7
Wiring coil couplers	7
Wiring smoke unit, strobe light, Mars light	8
Installing Railsounds 4.0	8
Final testing	9
Steam locomotive installation	10
Mounting the program/run switch	10
Mounting the speaker	11
Mounting and connecting the rear coil coupler	11
Wiring the motors and pickup wires	12
Mounting the reed switch	13
Wiring the reed switch	15
Connecting the smoke unit	16
Wiring the rear light	17
Reinstalling the tender shell	17
Die cast shells with plastic coal loads	17
Brass & die cast shells	17
Testing your installation in steps	18
Troubleshooting	20
Programming your locomotive	21
Command Control functions	21
SAW Board overview (reference for installing)	23

The last page of this instruction manual features an overview of the entire SAW board and clearly illustrates where each and every harness plugs into the board.

Please remove this sheet for easy reference throughout your installation.

Introduction

Congratulations on your purchase of a Train America Studios SAW board. If you are wondering what SAW stands for, it stands for Sunset, Atlas, Weaver. The board you are about to install is the same board that is found inside these manufacturers Command Controlled and Railsounds equipped locomotives from the factory.

The SAW boards feature the most reliable motor driver available on the market today and best value for your dollar.

A SAW board incorporates both Command Control and Railsounds 4.0 on one small platform. Each SAW board is rated at 8 amps (or 15 amps if so ordered), which means that your SAW board is overrated for the amount of amperage your motors will pull at a full stall. Another improvement is the addition of the plugs and harnesses that provide reliable connections and are easy to install. We are confident that our SAW board will fulfill your expectations of an easy-to-install reliable Command Control and Railsounds board that will provide many years of enjoyment.

Please read through these instructions carefully before beginning the installation. Familiarize yourself with the installation process, if you have any questions, please call our technical assistance line at (330) 533-7181 Mon-Fri 10a-6p EST. In the event you are uncomfortable performing the installation you can send your locomotive to TASTudios for installation. Please call us prior to sending us any locomotive for current installation rates and turn around times.

Upgrade Kit Contents

Your new SAW board upgrade kit contains several components that will be necessary for you to complete you installation. These items are as follows;

- 6 2-wire harnesses with connector these harnesses are used for front coupler, front light, motor leads, power input, rear light and rear coupler
- 1 2-wire harness with SPDT slide switch used for Program/Run switch
- 1 3-wire harness used for smoke unit/strobe light/ mars light
- 1 3-position 2-wire harness with speaker used for speaker connection
- 1 2-position 1-wire harness with self-adhesive copper strip used for antenna
- 1 Reed switch & rare earth magnet (steam upgrades only)
- 1 Package of 5 wire nuts, 2 small screws and nuts, 2 #4 self tapping screws
- 1 Strip of thick double-sided tape and thin double-sided tape

Each 2-wire harness has the ends of the wires partially stripped. Throughout the installation process you will be required to connect these wires to various existing wires inside your locomotive. We recommend tinning the connection with flux or soldering paste and soldering the connections. We also highly recommend covering these solder connections with heat shrink tubing. Flux, solder and heat shrink tubing can be purchased from Radio Shack.

We recommend using a 63/37 Rosin core Solder for soldering your wiring connections. A standard 25-watt pencil tip soldering iron works best for this application. You can use the wire nuts that are included in the kit, however most installations are somewhat tight and wire nuts take up valuable space that can be conserved by soldering the connections and covering them shrink tubing. The choice is ultimately up to you.

Installation Format

These instructions are designed for both AC motored steam and diesel locomotives and are so labeled “Diesel Installation” and “Steam Installation”. The installation process will be performed in a series of steps. Please follow these steps closely and the installation will go smoothly. In addition to installing the SAW board in steps you will be prompted to test the locomotive in steps as well. This testing procedure will allow you to isolate any potential backwards wiring and correct the problem before moving to the next installation phase.

Diesel Installation

Begin your installation by removing the shell of the locomotive. Remove all the existing electronics or mechanical control devices (i.e. E-Units, battery brackets, horns, etc.). Use care when removing these

electronics. Some locomotives will have small circuit boards designed specifically for controlling constant voltage lighting. You can easily identify these boards, as they will be connected to pickup and ground on one end. The other end will have two or more connections to lights (usually located in the front of the locomotive and/or the interior cab lights). If your locomotive has these constant voltage boards DO NOT remove them or cut any wires from them, as you will want to include them in your installation. Cut the wires as close to the preexisting components as possible (excluding of course any constant voltage boards previously mentioned). This will provide plenty of wire to work with and prevent you from having to lengthen wires later in the installation. If a speaker was originally located on the frame and mounted in a baffle, do not remove it if possible. Visually check to see if there is enough space to fit the SAW board on the frame by leaving the speaker in place. If not, remove the speaker, but save the baffle, you will be reusing it later in the installation process.

After you have removed the existing electronics you should be left with a bare frame. Decide where you want to place the SAW board. Keep in mind that the SAW board has plugs for the front light and coupler on one end of the board and plugs for the rear coupler and light on the opposite end of the board. See the diagram in the beginning of the installation instructions that illustrates the front and rear ends of the board. Placing the board with the front light and coupler leads towards the front of the locomotive will save you from having to lengthen wires later, however, if the board will not fit in this fashion you can always install the board backwards, you will just have to lengthen some wires. Once you have determined where to position the SAW board decide whether you will be mounting the board to the frame with the #4 self-tapping screws provided or with double-sided tape. If you decide to mount the board with the screws provided now is the time to drill the mounting holes. Use a 3/16" drill bit. DO NOT mount the board yet! Instead move on to "Installing the Program/Run Switch" and "Fuel Tank Speaker Mounting".

Installing the Program/Run Switch

Locate where the program/run switch will be mounted. Often times this switch is mounted under the SAW board. If it will mount under the SAW board go ahead and mount it now. Use the small #2 screws and nuts provided to mount it to an existing hole in the frame or use the thin double-sided tape to attach it to the end of the fuel tank or bottom of the frame. The position of this switch is ultimately your decision

We recommend that if the switch is mounted parallel with the long side of the frame that the two wires, which are soldered to the switch, are towards the front of the locomotive. (This is the program position.) The diagram below illustrates the run/program switch positions;

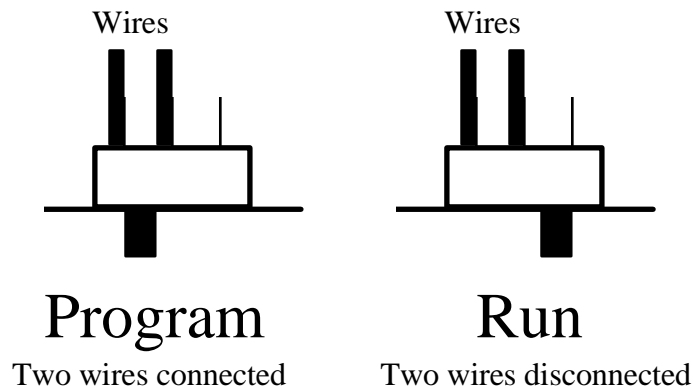

Fuel Tank Speaker Mounting

If the speaker will fit into the fuel tank now is the time to install it. Especially if the screws holding the fuel tank to the frame are accessed from the topside of the frame. Make sure the speaker is securely fastened in place. A loose speaker will result in very poor performance. We recommend the cone of the speaker point downwards and the magnet of the speaker point upwards. If mounting brackets are not supplied in the fuel tank

we recommend holding the speaker in place with a liberal amount of hot glue or similar adhesive. Reattach the fuel tank to the frame. Route the speaker wires up through the frame. If the speaker will not fit inside the fuel tank proceed with the installation. We will cover a frame-mounted speaker later in the instructions.

Mounting the SAW Board

Upon initial inspection of the SAW board you will notice a large aluminum heat sink on the bottom of the board. This heat sink can be used for firmly mounting the board to the chassis of the locomotive with the self-tapping screws provided or it can be affixed to the chassis with double-sided tape. The heat sink will never generate enough heat to do any damage to either the tape or any other portion of the locomotive. The application (i.e. the locomotive you are installing the board into) really determines how the board will mount to the frame. Be careful the heat sink does not interfere with any of the wires coming through the frame. Be certain that all moving wires (such as those attached to the trucks) have sufficient clearance, otherwise a short circuit may occur once the shell is attached.

You will notice the heat sink has two long holes cut out of it where the heat sink bends downward. These holes are used to route any wires that come up from under the board. Feel free to route both the speaker plug and the program/run plug through these holes if necessary. It is also okay to cut the heat sink if required. You can cut the flat surfaces of the heat sink, but do not cut beyond the bends. These bends represent the minimum amount of material allowable for proper heat sinking. To cut the aluminum simply score a line where you want the aluminum to break and bend it back and forth until it snaps off. Be careful not to put too much pressure on the components attached to the heat sink, while these components are durable they are breakable. Most installations will not require you to cut the heat sink though.

Once the program/run switch has been mounted route the 2 position wire harness through the frame and leave it unattached for the time being. After the speaker in the fuel tank has been installed and the wires routed through the frame leave it unattached for the time being.

Go ahead and mount the SAW board with either the self-tapping screws or the double-sided tape. If your speaker is to be mounted to the frame, make certain you have sufficient space to mount the speaker once the SAW board has been attached. Check to make sure the SAW board, along with the three plug-in cards will clear the inside roof of the shell. If the speaker did not fit into the fuel tank make certain there is enough room inside the shell to accommodate the speaker (and any associated baffle). If the board does not clear the shell find an alternate mounting location and affix the board to the frame. Ensure the SAW board is in position and firmly mounted to the chassis before proceeding.

Program/Run and Speaker Wiring

Once the SAW board has been securely mounted to the frame plug the Program/Run switch harness into the plug labeled “PRG”. Plug the speaker harness into the plug labeled “SPKR”. Refer to the diagram on the last page of the instructions for the exact locations of these plugs. If you discover the wires need to be lengthened, go ahead and lengthen them. Keep in mind that if the program/run switch and/or the speaker leads come from below the SAW board it is best to wrap the wires over the short edge of the board and then connect them. This will help conserve space and make life easier when reinstalling the shell. It is okay to route the wires through the three sets of 24-pin connectors on the SAW board. Doing this helps keep the wires from exceeding the width of the board and it makes for a cleaner looking installation.

If your speaker did not fit into the fuel tank now is the time to mount it to the frame. If the original speaker came with a baffle (or enclosure) we recommend you reuse it. The overall volume will be louder if a baffle is used, as opposed to not using one. If your locomotive did not have a speaker or a baffle we recommend making one from either a Styrofoam or paper cup or by using the cardboard insert from a paper towel roll. The magnet of the speaker should be installed inside the baffle, with the cone facing outwards. Once you have the speaker mounted in a baffle mount it vertically on the frame using a small piece of the thick double-sided tape to hold it in place. Be sure the speaker does not exceed the dimensions of the diesel body sides! We recommend

you use either hot glue or a similar adhesive to provide additional support for the speaker mounting. A loose speaker will result in poor performance. It is important to install the speaker now, so that any wiring between the SAW board and the speaker can be properly routed in the following steps. Once you have the speaker securely mounted to the frame plug the speaker harness into the “SPKR” plug on the SAW board. (refer to the last page diagram for clarity).

Installing the Antenna

In the coming steps you will be required to test the locomotive in stages. To complete these tests you will need to have the antenna connected to the board so it can receive the radio signal being transmitted from the command base. Locate the antenna harness (a short strip of copper tape with a wire soldered to it). Insert the antenna harness into the plug labeled “ANT” (refer to the diagram on the last page of the instructions). Do not remove the paper strip on the antenna. Leave this strip alone until the installation is almost complete. When testing the installation make certain the antenna DOES NOT come in contact with ground, otherwise the command receiver will be damaged.

Wiring the motor and pickup wires

To begin wiring locate the center rail pickup roller wires (most engines will have 2 wires, while others may only have one pickup wire). Locate the ground wires (again, most locomotives will have two ground wires, while others may only have one). Most commonly red wires are center rail pickup and black wires are ground, but this does not always hold true. Visually follow each wire to where it originates from to verify you have the correct wires. Install one 2-wire harness into the SAW board connection labeled “PWR”, refer to the diagram on the back cover for reference. Connect the pickup roller lead(s) (often times RED) to the outermost wire on the SAW board “PWR” connector. Connect the ground lead(s) (often times BLACK) to the innermost wire on the “PWR” connector. Again, refer to the diagram on the back cover for clarity. If you have a locomotive that was originally equipped with a constant voltage lighting board now is the time to connect the red and black input wires to pickup and ground (red will connect to the to outermost wire in the PWR harness and black will connect to the innermost wire in the PWR harness.)

Locate the motor brush wires. On all AC motored locomotives each motor will have a total of 3 leads per motor. These wires will most often be Blue, Yellow and Green (but not always, again, follow the wires to see where they terminate). Insert a 2-wire harness into the “M1, M2” plug. Connect two motor brush leads of the same color to one of the black wires in the “M1, M2” harness. Connect the remaining two motor brush leads, again, of the same color to the other black wire from the “M1, M2” harness. Finally, locate the Green field winding wire on the center tab of the motors. Connect both Green field winding wires to the only green wire on the SAW board (located under the center Railsounds Audio Board). This is a gamble, you have a 50/50 chance of the locomotive starting in forward, and there is nothing you can do but take a shot in the dark.

Once you have connected the motor brush leads and the field winding leads to the SAW Board you need to install the noise immunity capacitors. (These capacitors help filter the noise generated by the AC motors that sometimes cause the couplers to fire randomly and the lights to flicker when they should be off.)

Locate the small bag containing four 1 microfarad 50 volt capacitors. You need to install one capacitor between each motor brush lead and ground. The diagram on the following page illustrates where to install these capacitors.

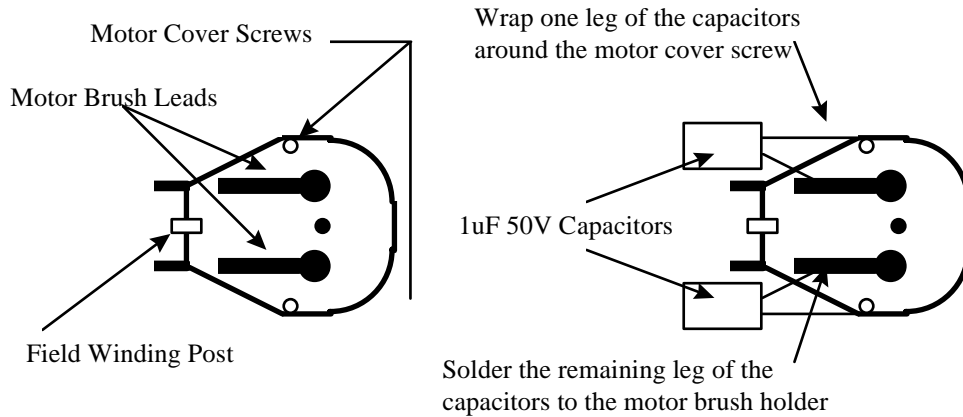

Overhead view of a typical AC Pulmor Motor

You have just completed the first phase of wiring. The board now has power and ground supplied to it as well as the motors connected (if the board was originally equipped with a constant voltage lighting board, this too should be connected at this time). Install the “R2LC radio receiver” board (shown on the diagram on the last page) on the SAW board and test this phase of the installation. Refer to the testing page (page 18) to test this stage of the wiring. If the locomotive starts out in reverse simply reverse the motor brush leads. And retest the locomotive to verify it starts out in forward. Proceed to the next step. The end result of this test should be that the locomotive starts moving in the forward direction when you turn the throttle (without even touching the DIR key).

Wiring the Lighting System

The lights on your locomotive will operate directionally at a constant voltage once they are connected to the SAW board. This means the front light will be on when the locomotive is moving forward and the rear is on when it is moving in reverse. The SAW board operates on a constant 18 volts AC track power. The output to the lights is a constant 12 VAC. Most Lionel locomotives are equipped with 12-14VAC bulbs. These bulbs can be connected directly to the SAW Board without any modifications at all.

Locate the front and rear lights on the locomotive. Identify if the front light has one wire or two. If it has only one wire then it picks up the ground from the frame and the single wire is hot. If it has two wires, then one wire is hot while the other is ground. Locate 2 of the two wire harnesses and plug one into the FLT socket and other into the RLT socket. The outermost wire from the SAW board is the hot lead, while the innermost wire is ground. Connect the FLT wires to the front light. Connect the RLT wires to the rear light. If you do not use the innermost ground wire simply clip the wire off at the plug and discard it. Headlight leads are not directional, so either wire can be hot or ground.

You can test the engine at this stage to verify the front light comes on upon initial power up and that the rear light comes on once you press the DIR button. It is recommended that you test this now to verify you wired the lights correctly. If you discover the lights are backwards, simply unplug and move the wire harnesses into the appropriate plugs. Retest the locomotive to verify the lights are correct.

Wiring Coil Couplers

If you have purchased coil couplers from TASTudios install them now. You will probably be required to remove the motor(s) from the trucks to install the couplers and/or the trucks from the frame. Once the couplers are installed route the wires up through the frame and to the SAW board. If you purchased your couplers from TASTudios then they already have a wiring harness. If the couplers were purchased from TASTudios simply plug the front coupler into the FCP plug and the rear coupler into the RCP plug. If they were the original factory-

equipped couplers you will need to locate 2 of the 2 position wire harnesses. Plug one harness into the plug labeled FCP and one harness into the plug labeled RCP.

Both wires from each coupler need to be connected to the wire harnesses. You will more-than-likely be required to lengthen at least one if not more of these wires to achieve this. Connect both leads from the front coupler to the wires from the FCP harness. Polarity makes no difference, you can connect either wire from the coupler to either wire in the harness. Repeat this process for the rear coupler using the wire harness from the RCP plug.

If you did not purchase the coil couplers for this installation they can always be added at a later time. Coil couplers, or the lack thereof will not affect the overall operation of your locomotive.

It is recommended that you test the coil coupler function and verify the couplers fire correctly; F coupler key fires the front coupler and R coupler key fires the rear coupler. If you notice the lights dimming when the couplers fire, this is normal.

Wiring a Smoke Unit or Strobe Light or Mars Light

If your locomotive is equipped with a strobe light or a Mars light, it can be connected to the SAW board and turned on and off from the remote. Locate the two wires that make up the strobe or Mars light (this may be a constant voltage board that controls the strobe or Mars light, if this is the case leave the light connected to the constant voltage board and locate the 2 wires that power this particular board). Next locate the 3 wire harness that was supplied with the kit. Insert the 3 wire harness into the plug labeled SMK. The outermost wire is hot and the center wire is ground. Connect the two leads from your light or constant voltage board to these two wires.

If you are adding a TASTudios Turbo Smoke unit with Diesel Accel feature to your locomotive you will use all 3 wires in the SMK harness. The diagram on the last page illustrates the function of each of these wires. Simply follow the instructions that came with your Turbo Smoke unit to install and wire to the SAW board.

It is recommended that you test the function of the strobe light, Mars lights or smoke unit now. Refer to the test page for testing procedures.

Installing Railsounds 4.0

The Railsounds circuit is already built into the SAW board. It incorporates what is known as a VCO circuit. The VCO circuit is what tells the Railsounds whether the locomotive is moving or not. The VCO is responsible for making the RPM's increase or decrease based on movement. This features occurs automatically, there are no adjustments you can make to this circuit.

In the beginning of the installation process you mounted the supplied speaker either inside the fuel tank or on top of the frame. If you have not already plugged the speaker into the SAW board locate the speaker harness now(a 3-position connector with only 2 wires, center position will be blank) and insert it into the plug labeled "SPKR" (refer to the diagram on the last page for reference).

Your Railsounds volume is already set to be at the highest level. The volume can be controlled from the remote using AUX1 + 4 to lower the volume and AUX1 + 1 to increase the volume. There is no need to install a potentiometer.

To test your Railsounds locate the two plug-in cards that make up the Railsounds circuit. These are referred to as the RS Audio board and the RS Power board. The diagram below illustrates what these boards look like from a side view so you can identify them.

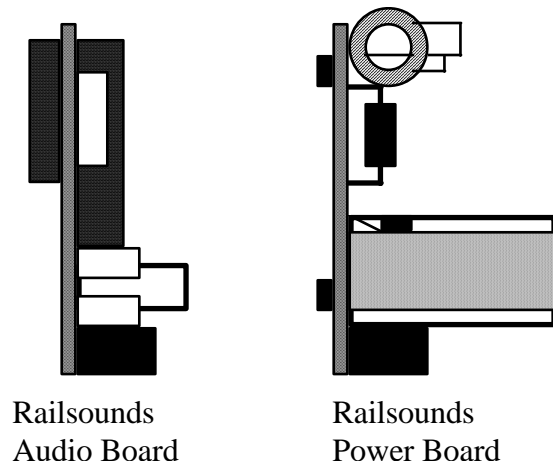

Once you have located the RS Audio and RS Power boards go ahead and plug them into the SAW board. Refer to the diagram below for their orientation. DO NOT plug these boards in backwards or you will damage the Railsounds and void the warranty.

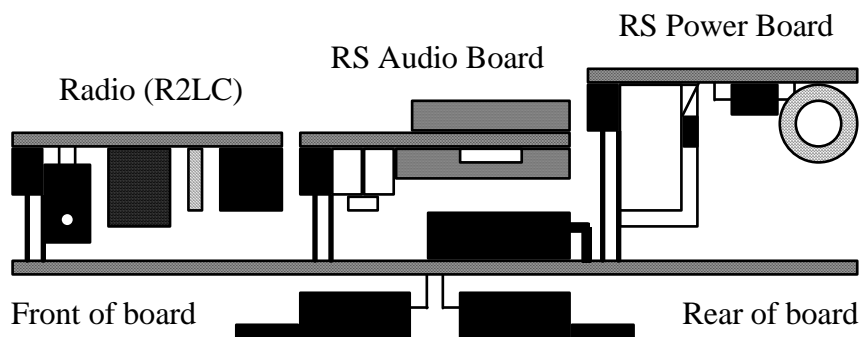

Once the Railsounds are plugged into the SAW board refer to the test page for testing.

Optional Mute Switch Installation

Your SAW board is equipped with a mute option. This is the switch that allows you to choose between Railsounds 4.0 and SignalSounds. (SignalSounds is only the horn and bell, no other sounds). You are not required to install a mute switch, nor are a switch is included in the kit for this. However, if you decide to include this step in your installation please call us at (330) 533-7181 Mon-Fri 10a-6p EST for complete details.

Final Testing

Your installation is 99% complete. Before you reinstall the shell please test the locomotive one more time to verify that each function is working properly. It will be much easier to correct any mistakes now before the shell is reattached.

After you have completed the final test it is time to reinstall the shell. Set the shell next to the frame of the locomotive up-side-down. Remove the paper backing from the antenna to expose the adhesive surface. Place the antenna in the center of the cab roof using the adhesive to hold it in place. Cover the copper antenna with some electrical tape. (Try to cover the entire exposed copper antenna. This will prevent any shorts from occurring should the antenna ever decide to fall off the roof in the future.)

Flip the shell right-side-up and set it back on the frame. Be careful you do not pinch any wires between the shell and the frame. Also take care to ensure the antenna wire is not touching the flywheels or any moving parts inside the shell. Reinstall the body mounting screws. That's it! The installation is complete. We

recommend that you perform one final test to verify that all the functions operate properly. In the event you encounter a problem it is probably caused by a pinched wire, especially if everything tested good on the last test you performed.

If you encounter any problems during the final testing sequence, please refer to the Troubleshooting section towards the back of this manual.

Steam Installation

Steam locomotive installations are unique in their own way. These instructions cover how to install the SAW board in any type of AC motored steam locomotive. The instructions are not intended to be specific to one manufacturer in any way. Please read through the instructions thoroughly before beginning the installation. This will allow you to fully understand the steps you will need to follow. Once you have read and understand the installation steps proceed with the installation. If you feel you cannot complete the installation, simply contact us at (330) 533-7181 Mon-Fri 10a-6p EST for current installation rates and turn around times.

In all steam locomotive applications the SAW board will install in the tender. In most instances you will need to install a wire tether between the locomotive and tender to make the necessary connections between the two pieces. When you are installing a new wire tether it is a good idea to have the shell off both the locomotive and tender. This will allow you to visually trace where each wire goes on both the locomotive and tender sides.

Go ahead and remove the tender shell. Once the shell is removed take out all the existing electronics or whistle. Do not clip any wires yet!

Once the tender shell has been stripped of the original electronics decide where you want to place the SAW board. If the locomotive was originally equipped with sounds remove the old speaker and replace it with the one provided in your SAW board kit (If the original tender used a baffle for the speaker save it, reinstall the new speaker in this baffle and mount it to the frame using the double-sided tape provided). Once the new speaker is in place visually check to see where you want to place the SAW board. Set the SAW board in place and by setting the shell on the frame, verify there is sufficient headroom to accommodate the SAW board in the position you have chosen. If there is not sufficient space move the board to where it will fit. In most instances you will be forced to place the rearmost end of the board towards the front of the tender to take advantage of the extra headroom under the coal load.

Upon initial inspection of the SAW board you will notice a large aluminum heat sink on the bottom of the board. This heat sink can be used for firmly mounting the board to the chassis of the locomotive with the self-tapping screws provided or it can be affixed to the chassis with double-sided tape. The heat sink will never generate enough heat to do any damage to either the tape or any other portion of the tender. The application (i.e. the tender you are installing the board into) really determines how the board will mount to the frame. Be careful the heat sink does not interfere with any of the wires coming through the frame. Be certain that all moving wires (such as those attached to the trucks) have sufficient clearance, otherwise a short circuit may occur once the shell is attached.

Once you have established the position of the SAW board you must decide how you want to mount it. For steam applications we recommend using the number 4 self-tapping screws included in the kit. If you decide to use the screws simply drill a 3/16" hole in the frame to accommodate the screws. You can also use either the thin or thick double-sided tape included with the kit if necessary. **DO NOT MOUNT THE BOARD YET!**

You will want to install the coil coupler prior to mounting the SAW board in the tender. We recommend you mount the coupler first just in case the screw for the truck falls under the SAW board. Once you have the coil coupler mounted to the truck you can permanently mount the SAW board on the frame.

Mounting the Program/Run Switch

Some tender frames will already have three holes stamped in it to accommodate a SPDT slide switch. If the tender has these holes install the Program/Run switch there using the two small screws and nuts provided in the kit. If the tender frame does not have preexisting holes for a switch you have two choices. One, you can drill

out three holes to accommodate the Program/Run switch. Two, you can mount the switch to the underside of the tender frame using a small piece of the thin double-sided tape enclosed. (We recommend the latter as it will not devalue the locomotive). When you mount the Program/Run switch we recommend you set it in place with the two wires towards the front of the locomotive and the single unsoldered pin towards the rear of the tender. The diagram below illustrates this.

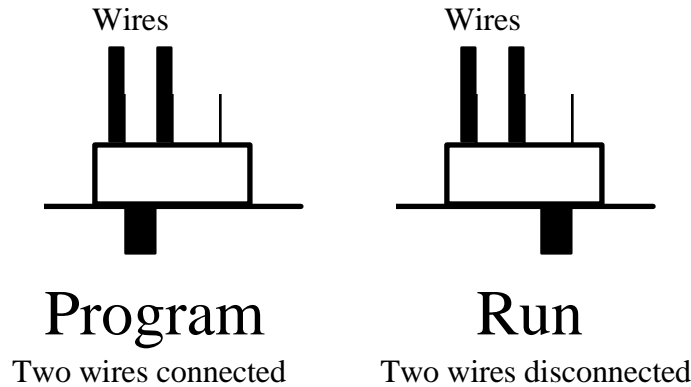

Once you have mounted the program/Run switch route the 2-wire harness to the “PRG” plug on the SAW board. (Refer to the diagram on the last page for clarity.)

Mounting the Speaker

If the locomotive was originally equipped with sounds then the tender frame already has a predetermined speaker mounting position (with holes drilled in the frame and often times mounting tabs). If this is the case mount the new speaker in this location. If the tender was not originally equipped with sound you may want to drill a series of 1/4” holes in a 2” diameter circular pattern to allow the sound to escape once the tender shell is reinstalled. It is also a good idea to firmly attach the speaker to the frame using hot glue or a similar adhesive. If the tender was originally equipped with a speaker baffle you will want to mount the new speaker in this baffle and securely affix it to the frame with the above mentioned adhesives.

Once the speaker is securely affixed to the frame route the 2-wire 3-position wire harness to the “SPKR” plug on the SAW board (refer to the diagram on the last page for clarity). After the speaker has been plugged into the SAW board proceed to the next step.

NOTE If you discover that the magnet on the speaker is too tall and the SAW board will not properly fit once the shell is reinstalled please contact TASTudios for a “pancake speaker”. Pancake speakers are available for an additional \$8.00. Most installations will not require this speaker, however, if yours does, please contact us at (330) 533-7181 Mon-Fri 10a-6p EST.

Mounting and Connecting the Rear Coil Coupler

If the tender was not originally equipped with a coil coupler and you purchased one to add, go ahead and mount it at this time. Once the coupler has been mounted you need to connect it to the SAW board. If the coupler was purchased from TASTudios it already has a 2-wire plug on the end. If this is the case, plug the harness into the plug labeled “RCP” on the SAW board (refer to the diagram on the last page). If the coupler was not purchased from TASTudios locate a 2-wire harness and plug it into the connector labeled “RCP”. Connect one wire from the harness to one wire on the coupler, repeat this step for the remaining wire(s). Polarity is not an issue, so either coupler wire can connect to either harness wire. Once the rear coupler is mounted proceed to the next step.

Connecting the Pickup Wires and Motors

Locate two 2-wire harnesses and plug them into the plugs on the SAW board labeled “M1, M2” and “PWR” (refer to the diagram on the last page for clarity). Because you will be installing a tether between the locomotive and tender you will be connecting wires from the harnesses on the SAW Board to wires in the tether. The chart below illustrates the recommended position of each wire in the tether.

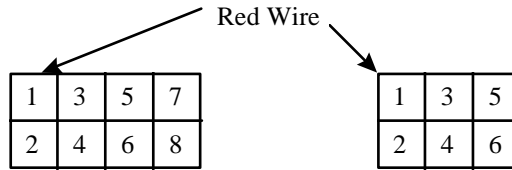

Recommended Wiring Order

- 1 = Red, AC Hot, Pickup Rollers
- 2 = Black, AC Ground (Loco Frame)
- 3 = Black, Motor Brush 1
- 4 = Black, Motor Brush 2
- 5 = Black, Field Winding
- 6 = Black, Front Light
- 7 = Black, Smoke Unit Hot
- 8 = Black, Not Used

NOTE we recommend you install the male side of the tether to the tender connections.

Once you have located and identified the function of each wire in the tether it is time to connect the wires to the wire harnesses. Locate the center rail pickup roller wire (AC Hot). Connect it to the outermost wire of the “PWR” harness. Locate the ground wire and connect it to the innermost wire of the “PWR” harness AC Ground). (Refer to the diagram on the last page for clarity).

Locate one motor brush lead wire and connect it to one of the two “M1, M2” harness wires. Connect the remaining motor brush lead to the remaining wire from the “M1, M2” harness. This is a shot in the dark, there is no way to get this right the first time. You will determine if the wires are connected properly when you perform your test. If the locomotive starts out in reverse, simply reverse the motor brush leads to correct this problem.

Please follow the guidelines below for connecting the opposite (female) side of the tether to the locomotive.

Modern Era Lionel Steam Locomotives

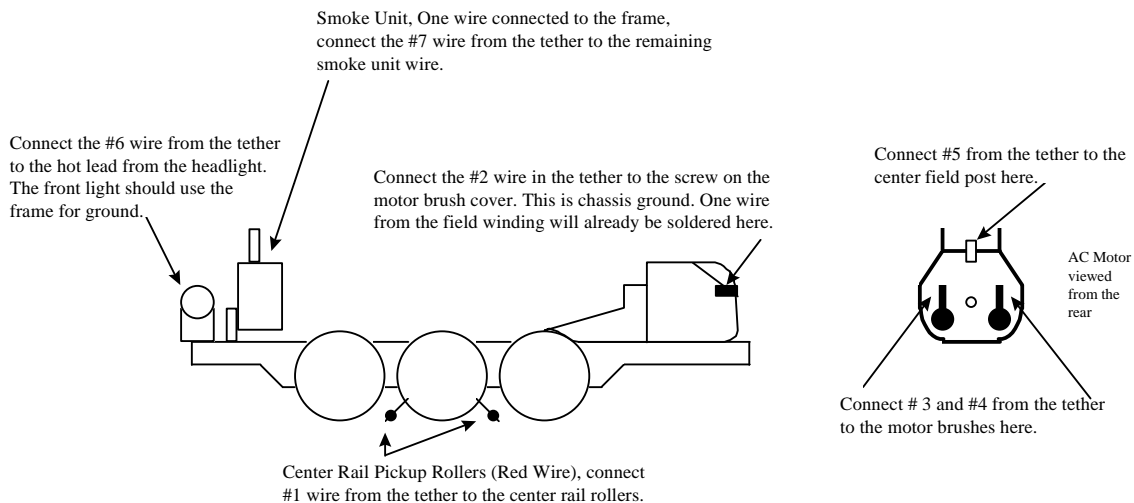

The diagram on the previous page illustrates how we suggest the wires be arranged in the new tether you installed. The opposite (female) side of the tether should connect to the following locations inside the locomotive.

Once you have the female side of the tether installed in the locomotive please refer to the testing page (page 18) to make certain the locomotive starts out in forward.

If your locomotive is equipped with a modern AC Pulmor motor please refer to the diagram below for the illustration on how to connect the noise immunity capacitors (the 4 small round capacitors in the clear baggie) to the motor brush leads. These capacitors will help keep the lights from flickering and the couplers from false firing. It is highly recommended that you install these caps.

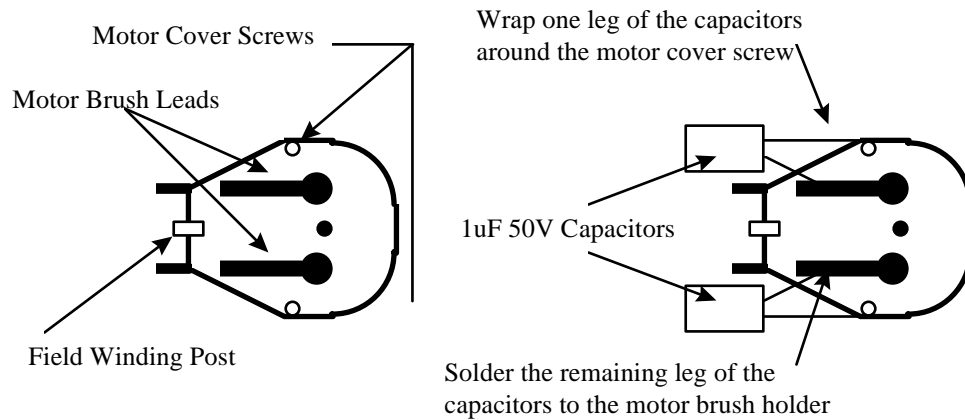

Overhead view of a typical AC Pulmor Motor

Mounting the Reed Switch

The SAW board uses what is known as a Reed Switch and a rare earth magnet to tell the sound system when to chuff. This method is used simply because the chuffing occurs as a result of speed and not motor voltage. (Motor voltage is inconsistent, especially with a heavy load versus just a couple of cars.) The reed switch is nothing more than two small pieces of metal that are normally open (not touching each other) inside a small, encapsulated, glass cylinder. Each time a magnet passes by the reed switch the two metal strips make contact with one another and a switch closure results. The switch closure is completing a circuit between the Railsounds board and AC ground. Each time the reed switch closes (that is to say each time the Railsounds sees a pulse of AC ground) the Railsounds makes a chuff sound. This is how the Railsounds 4.0 chuffing works.

By mounting the reed switch and magnet on the tender wheel you will get approximately two chuffs per revolution. This is because in most instances the tender wheels are at least half the diameter of the drivers, so for every one revolution of a driver, the tender revolves twice

The reed switch will be mounted close to the backside of one tender wheel. A magnet will be mounted to the backside of that wheel. Each time the wheel revolves the magnet will pass the reed switch and generate a chuff pulse.

Locate the small plastic bag that contains the reed switch and a rare earth magnet. The reed switch will look like a small black cylindrical object with two wires protruding from one end. The reed switch should be mounted to the tender truck bolster (this is the piece that actually holds the two side frames together and it is the piece that connects the truck to the tender frame). We have included several diagrams showing recommended mounting positions for the reed switch.

Keep in mind that the wires from the reed switch need to be routed through the frame and connected to the SAW board inside the tender. So be certain that the wires do not get pinched when the truck swivels. Also remember to compensate for the back-and-forth motion of the axle in the side frames.

The reed switch can be mounted to the truck bolster with super glue. We recommend you use Zap A Gap CA+ in conjunction with an accelerator called Zip Kicker. The accelerator makes the super glue dry instantly and greatly reduces the time spent mounting the reed switch. (These adhesives can be purchased from any hobby shop or craft store.)

NOTE For “centipede” tenders (such as Union Pacific articulated steam tenders) we highly suggest mounting the reed switch to the front most truck that swivels. A lot of times the wheels in the centipede truck do not always rotate. This will cause the chuffing to cut in and out erratically. On conventional tenders it is recommended the reed switch and magnet be installed on the front most wheel in either the front or rear truck (see diagram for clarity) and never the center wheels for trucks with three axles. If the tender you are installing the reed switch to was originally equipped with a hall effect sensor and has a large round magnet attached to one of the axles, move the axle with the magnet as far away from the reed switch as possible. Otherwise the magnetic flux from the axle magnet may interfere with the reed switch operation.

There is no exact distance the reed switch should be spaced away from the magnet, as magnetic flux varies from one magnet to the next. The best advice we can give you is to get the reed switch as close to the magnet as possible without the two hitting each other. The diagrams on the next page illustrate what we have just covered.

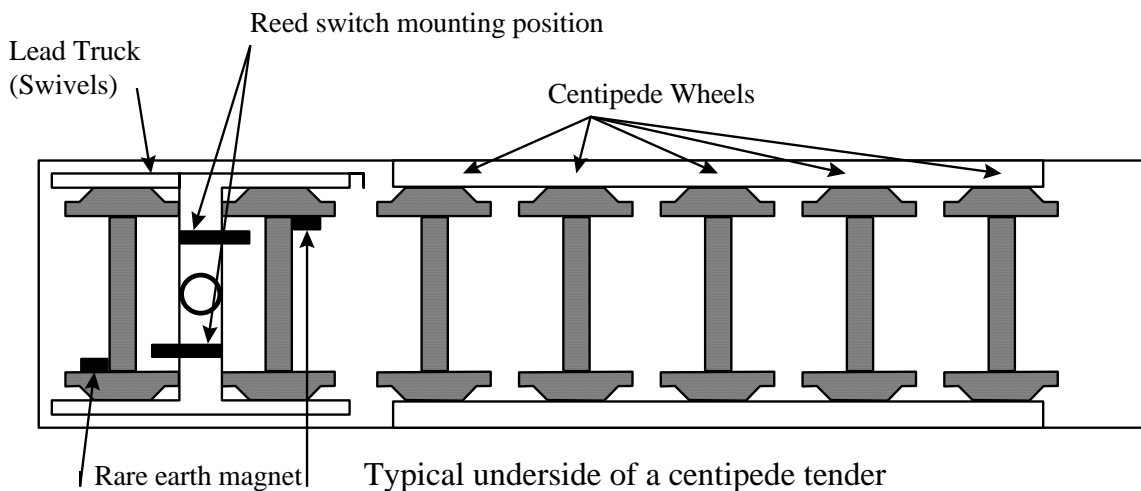
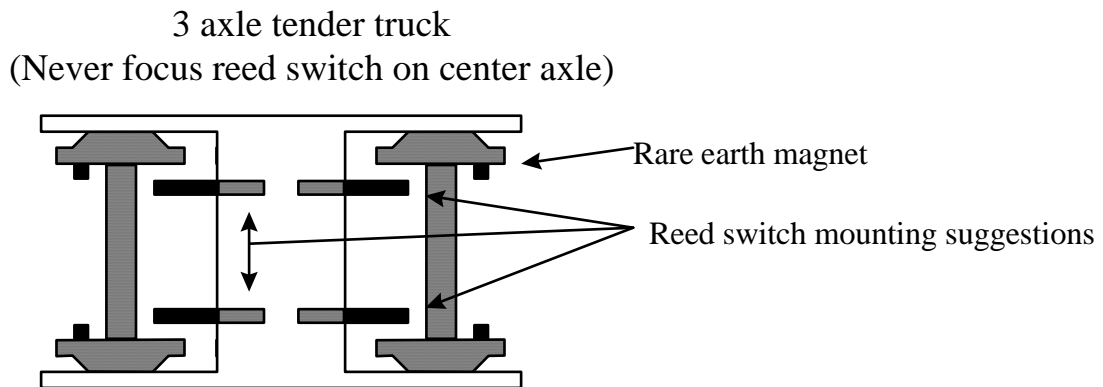

Overhead view of tender truck

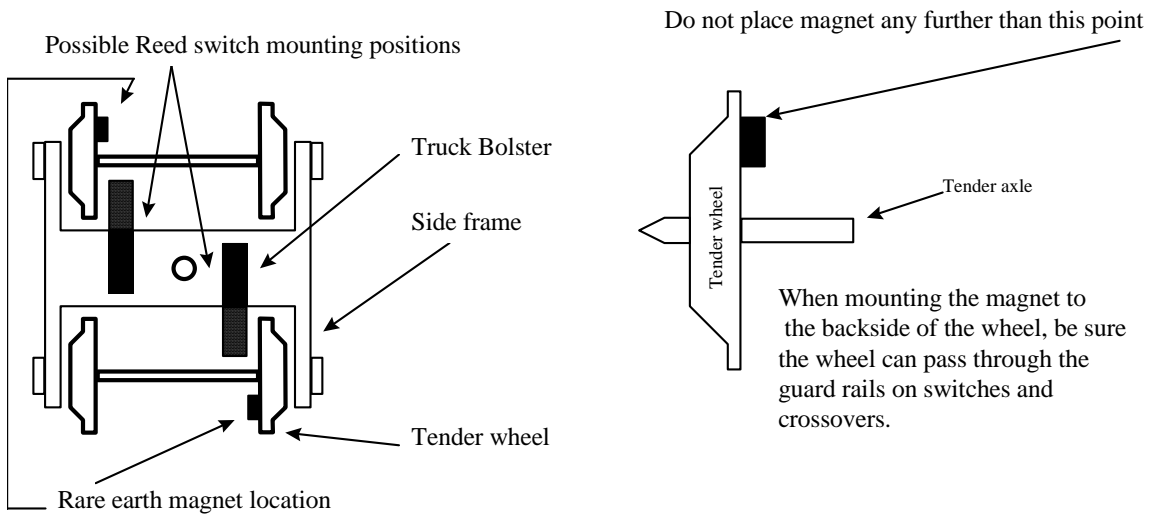

Finally, be certain the magnet does not get hung up on the reed switch (you should be able to spin the wheel without it stopping suddenly while rocking the tender from side to side).

Once the reed switch has been mounted in place affix the magnet to the backside of the wheel with a small dab of super glue to hold it firmly in place. Remember, the magnet should be able to clear the guardrails on your switches and crossovers, so don't mount it too close to the outside edge of the flange.

If you would like to test the reed switch prior to connecting it to the SAW board you can do so. You will need the following to test the reed switch; a conventional AC transformer, a spare piece of wire and a 12-14 VAC bulb. Connect one wire from the reed switch to the ground terminal of your transformer. Connect the other wire from the reed switch to one side of the bulb (ground side). Connect a spare wire to the hot side of your transformer and then to the remaining side of the bulb (hot side). Turn the transformer on to approximately 10 VAC. Slowly spin the axle the magnet is attached to. The light should flash on each time the magnet passes the reed switch. If it does not, simply adjust the position of the reed switch until the light comes on when the magnet passes the reed switch. The diagram below illustrates the wiring for this test.

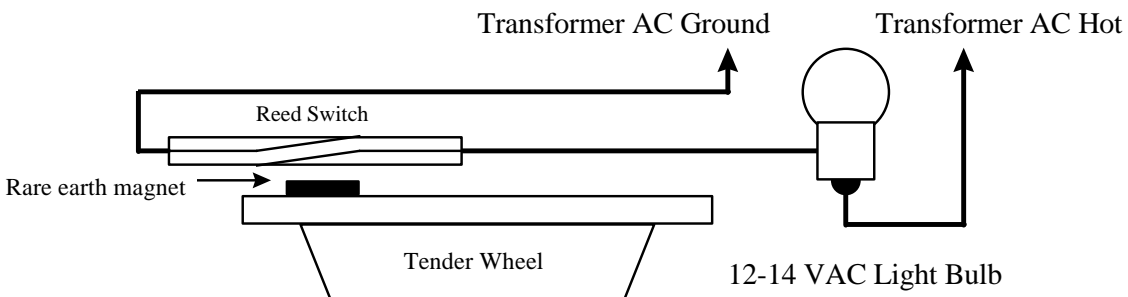

Wiring the Reed Switch to the SAW Board

There are a total of two wires attached to the reed switch. One of these wires needs to connect to a ground terminal. Locate a 2-pin wire harness and connect it to the "FLT" plug on the SAW board. (Refer to the diagram on the last page for clarity). Connect one wire from the reed switch to the innermost AC ground wire in the FLT harness. (Polarity on the reed switch does not matter, either wire will do.) Connect the remaining wire

from the reed switch to the black wire on the SAW board coming from pin 6 of U6. (See diagram on the last page for clarity).

Your Railsounds volume is already set to be at the highest level. The volume can be controlled from the remote using AUX1 + 4 to lower the volume and AUX1 + 1 to increase the volume. There is no need to install a potentiometer.

To test your Railsounds locate the two plug-in cards that make up the Railsounds circuit. These are referred to as the RS Audio board and the RS Power board. The diagram below illustrates what these boards look like so you can identify them.

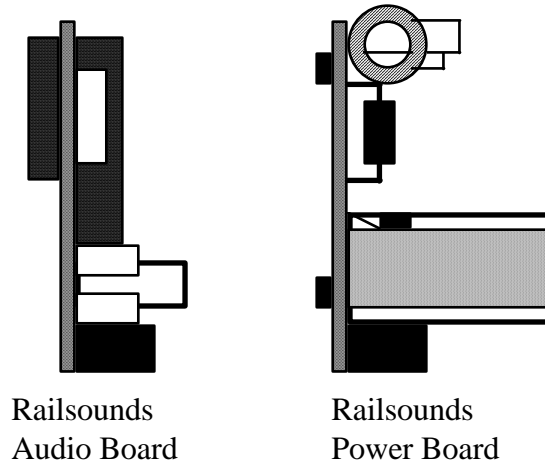

Once you have located the RS Audio and RS Power boards go ahead and plug them into the SAW board. Refer to the diagram below for their orientation. DO NOT plug these boards in backwards or you will damage the Railsounds and void the warranty.

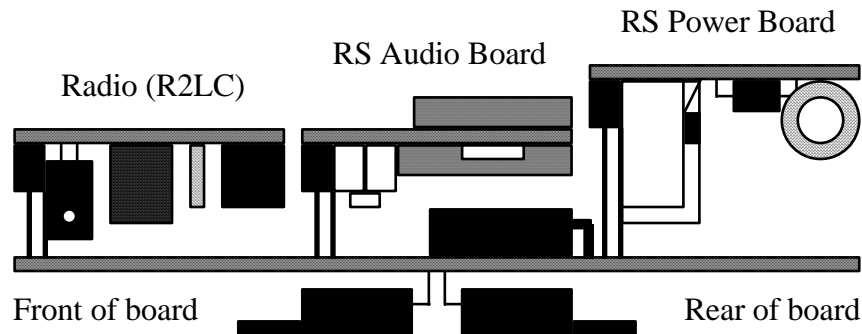

Once the Railsounds are plugged into the SAW board refer to the testing page (page____) for testing. This test will verify the reed switch is working properly in conjunction with the Railsounds.

Optional Mute Switch Installation

Your SAW board is equipped with a mute option. This is the switch that allows you to choose between Railsounds 4.0 and SignalSounds. (SignalSounds is only the whistle and bell, no other sounds). You are not required to install a mute switch, nor is a switch included in the kit for this. However, if you decide to include this step in your installation please call us at (330) 533-7181 Mon-Fri 10a-6p EST for complete details.

Connecting the Smoke Unit

If your locomotive is equipped with a smoke unit you will want to connect the smoke unit to the SAW Board. This will allow you to turn the smoke unit on and off from the remote. Locate the 3-pin wire harness with all three wires. Plug this 3-pin harness into the plug labeled “SMK” (refer to the diagram on the last page

for clarity). Connect the #7 wire from the male side of the tether to the outermost wire in the SMK harness. The outermost wire is the smoke hot lead. The smoke unit will get its ground from the locomotive frame. Once the #7 wire has been connected verify the #7 wire from the female side of the tether has been connected to the smoke unit hot lead on the locomotive. (The diagram on page 12/13 will help you identify this wire).

Wiring the Rear Light

If your locomotive is equipped with a rear light follow these instructions, otherwise skip to the next step. Locate a 2-pin wire harness and connect it to the plug on the SAW board labeled “RLT” (see diagram on the last page for clarity). Connect the 2-position wire harness to the two wires on the rear light. If your rear light only have a single wire (and receives the ground from the tender frame) connect the single light wire to the outermost wire in the RLT harness.

Reinstalling the Tender Shell

In most instances your tender shell will be made of brass or die-cast. The entire tender shell will be constructed of this material. If this is the case please refer to “Brass or Die Cast Tender Shells”. However, if your die cast tender shell has a plastic coal load you get away easy. If this is the case refer to “Die Cast Shells with Plastic Coal Loads”.

Die Cast Shells with Plastic Coal Loads

Set the shell next to the frame of the tender up side down. If you have not already installed the rear light do so now. We recommend using hot glue or a similar adhesive to hold it in place. If you have not already installed the antenna locate the 1-wire 2-position harness with the copper antenna attached to it. Connect this harness to the “ANT” plug on the SAW board. Carefully remove the paper strip on the backside of the copper strip and adhere it to inside of the plastic coal load. Make sure the antenna does not come in contact with the die cast shell. If you need to cut the antenna to prevent it from touching the die cast shell do so now. Cover the exposed copper with electrical tape to prevent a short circuit from occurring in the event the antenna should ever sag. Finally, make sure you have connected the marker light leads to the pickup and ground leads in the PWR harness.

Simply set the tender shell on the tender frame and reinstall the original screws you removed at the beginning of the installation. Perform one final test on the locomotive to ensure all the features are functioning properly. Refer to the testing page (page 18) to complete this test.

If you should encounter a problem simply backtrack the installation steps to undo whatever is wrong. OR refer to our troubleshooting page in the back of this manual.

Brass or Die Cast Tender Shells

Once you have finished the final test of the locomotive (after having installed the reed switch) you are ready to tackle the most time consuming and frustrating part of the installation. Reinstalling the tender shell. The reason this can be the hardest part of the installation is because the tender shell must be electrically isolated from the tender frame in order for the SAW board to receive a clear radio signal from the command base. The tender shell will become the antenna. The antenna cannot touch ground, otherwise the signal will be lost and the engine will revert back to conventional mode. We can assure you that once the shell is isolated the signal reception will be fantastic!

The reason this is so difficult is two-fold. First you cannot see the radio signal. The device that allows you to see the radio signal sells for approx \$25,000.00, so neither of us will be running out to buy one tomorrow. Second, a slight hairline tear in the electrical tape can allow the shell to touch the frame and totally defeat the isolation. So, please be patient with this segment of the installation process. We would not expect you

to do this if it could not be accomplished. It may take a few tries, but it will work. We've been using this method for over four years now with great results.

Brass Shells only *Most brass tender shells are attached to the tender frame with miniature brass screws. If this is the case with your tender shell we highly recommend drilling the holes oversize to accommodate the #4 nylon screws we have provided for you. These screws are much more durable than nylon screws the same size as the original brass screws. Drill the tender frame holes over using a 3/16" drill bit. Drill the 4 screw holes on the 4 corners of the shell at 7/64". This will allow you to use the nylon screws provided to reattach the shell to the frame.*

Set the shell next to the frame of the tender up side down. If you have not already installed the rear light do so now. We recommend using hot glue or a similar adhesive to hold it in place. Locate the 1-wire 2-position harness with the copper antenna attached to it. Connect this harness to the "ANT" plug on the SAW board. Carefully remove the paper strip on the backside of the copper antenna and adhere it to the inside center roof of the shell (make sure that any excessive paint is scraped away so the copper strips makes an electrical connection with the die cast or brass shell). Cover the exposed copper with electrical tape to prevent a short circuit from occurring in the event the antenna should ever sag. Finally, make sure you have connected the marker light leads to the pickup and ground leads in the PWR harness so they are illuminated all the time.

Begin by using black electrical tape to tape off the perimeter of the tender frame (basically everywhere the shell comes into contact with the frame). We recommend you leave an excessive amount of overhang with the tape. This will look tacky at first, but once the shell is sealed and the nylon screws are installed you can carefully cut the tape with a sharp X-Acto knife. Be certain that the electrical tape covers both the top of the tender frame and the sides of the tender frame, be especially careful to ensure the corners are covered. Once you are satisfied the frame is covered adequately carefully set the shell onto the frame and *gently* push the frame into the shell until it is properly seated.

Before you install the nylon screws we highly recommend you run a quick test to ensure the tape did not tear. If, when you power up the track the sounds come on immediately and the locomotive does not respond to any commands you will know the tape has torn somewhere. If the sounds do not come on when power is applied then the tape may not have torn. If this is the case (no sound at power up) run the engine around the track a few times trying different commands such as whistle, bell, Tower Com, etc. Be sure to run the engine in both directions while trying various commands. If the locomotive receives the commands without hesitation return to the bench and install the nylon screws. If the tape is torn return to the bench and remove the old tape and install new tape. Repeat the above process until it works properly. (This is the frustrating part we mentioned earlier.)

When installing the nylon screws you may be required to cut the screws down in length, this is okay, the nylon screws are very durable. Once you have the nylon screws installed take the locomotive back to the track and perform the above test again. If the locomotive responds flawlessly, Congratulations, you got it on the first try! If the locomotive does not respond and the sounds come on at power up, head back to the bench and start over, the tape obviously tore somewhere between the frame and the shell when you installed the screws.

As we mentioned above this may take several tries. Do not lose hope! It will work! If you get frustrated put it down and walk away for a while, sometimes this is the best solution. If all else fails, give us a call.

Testing your Installation in steps

This testing sequence is designed for both steam and diesel applications. Each segment of testing will have notes on what plug-in boards should be installed on your SAW board to properly complete the testing phase. If you have any questions while testing your locomotive please feel free to contact us at (330) 533-7181 Mon-Fri 10a-6p EST.

Please ensure the Lionel Command Base is connected to both outside rails of the track and is plugged into the wall (the green light will illuminate when it is powered). You will need to be able to turn on and turn off at least 18 volts of AC power to the track as well.

Before you begin any testing please ensure the antenna is connected to the SAW board. If it is not please locate the 1-wire harness with a copper antenna soldered to it. Plug this harness into the plug on the SAW board labeled "ANT". (Refer to the diagram on the last page for clarity.) Make sure the antenna is not touching ground! Leave it dangle in the air for all your testing.

Step 1; Programming the locomotive

Note you will need to have the R2LC radio receiver plugged into the SAW board. The RS audio and power boards are not required for programming the locomotive.

Set the program/run switch in the program position (where the arm is connecting the two wires). Place the locomotive on the track and apply 18 VAC power. Using the Cab-1 remote press the following keys

ENG + 1 + SET now press ENG + 1 + AUX1 + 8.

Slide the program/run switch to the run position (where the arm is NOT connecting the two wires). You have just programmed the engine as ID number 1.

Step 2; Startup Direction

Place the engine on the track and turn the 18 volts of track power on. Using the Cab-1 press ENG + 1 then turn the red throttle clockwise. The locomotive will begin moving. Ideally it should start moving in the forward direction. If it starts out in reverse simply reverse the motor wires at the plug on the 2-wire harness. Press the DIR key and turn the throttle clockwise again. The locomotive should begin moving in the opposite direction. If you had to reverse the motor leads repeat this test to ensure the locomotive starts out moving in forward.

Step 3; Diesel lighting

If the lights on your locomotive are in the shell, and not mounted to the frame, skip this step for now. You can always check this later. Place the locomotive on the track and apply 18 volts of AC power. Using the Cab-1 remote press ENG + 1. The front light(s) should come on immediately at power up. Turn the throttle clockwise and watch that the front light does not dim out. Press the DIR button. The front light should turn off and the rear light should turn on. Turn the throttle clockwise and watch the rear light does not dim down. If the lights come on in opposite directions of travel simply reverse the harnesses with the FLT and RLT plugs. If they come on in the correct direction leave them alone.

Step 4; Coil Coupler Testing

Place the locomotive on the track and apply 18 volts of track power. Using the Cab-1 press ENG + 1. Press the F coupler key, the front coupler should fire (open). Now press the R coupler key, the rear coupler should fire (open). If you have a steam engine without a coupler on the front of the locomotive the front coupler key will have no effect. If the rear coupler opens when you press the F key and vice versa, simply reverse the coupler harnesses with the FCP and RCP plugs on the SAW board.

Step 5; Smoke Unit, Strobe Light or Mars Light Testing

Place the locomotive on the track and apply 18 volts of track power. Using the Cab-1 press ENG + 1 then press AUX1 + 9. The smoke unit, strobe light or Mars light should turn on and stay on. Press AUX1 + 8 and the unit should turn off. If the smoke unit sounds as though it is pulsing please go back to the Step 1 and reprogram the locomotive. If after reprogramming the problem persists, recheck the wiring and make any necessary corrections.

Step 6; Railsounds 4.0 Testing

Place the locomotive on the track and apply 18 volts of track power. Using the Cab-1 press ENG + 1 + AUX1, the sounds should commence the start up sounds and start idling. (If you connected the mute switch and sounds do not come on, slide the switch to the opposite position and repeat the process). Press the Whistle/Horn key and the whistle should blow. Press the bell and the bell should start ringing. Turn the throttle clockwise (if you have a steam locomotive it should begin chuffing) (a diesel will rev up the engine sounds). Once you have verified the sounds work (by completing the steps above) return to the bench to complete the installation.

Step 7; Final Testing

To complete the final testing simply repeat steps 1 through 6. Make certain all the functions are working properly and the engine is receiving a good signal from the command base. (This will be apparent on diesels if the front light is NOT flickering. If your steam locomotive receives all the commands you send to it and does not hesitate during any of them you will know the tender is electrically isolated.) If you encounter any problems not listed in the testing steps, please refer to the Troubleshooting page for further details.

Troubleshooting

<u>Symptom</u>	<u>Correction</u>
Engine takes off, no control whatsoever	Check to ensure the command base is plugged in and is Connected to the outside rails. Also make certain it is Receiving Cab-1 signals by verifying the red light flickers When commands are sent. Is the antenna touching ground? Is the antenna touching a circuit board?
Engine seems to strain, even without a load	Be certain the motor leads are not touching ground or the body of the motor. Check for pinched motor wires.
Lights flicker erratically when sitting still	Place your hand over the locomotive. If the light stops flickering the antenna is not receiving the command signal. Make sure the antenna is not touching ground or a circuit board.
The rear light flickers when moving forward and vice versa	You have a poor ground for the light. Add an additional wire To the ground side of the light and connect it directly to a Plug on the SAW board.
The couplers fire randomly, and I did not press the F or R key	Check the ground wire for the coupler. False Fires are caused by a poor connection to ground. Make sure the copper coil on the coupler is not shorting against ground when the truck swivels.
Smoke unit fan does not stay on, it pulses	Reprogram the locomotive. Follow the programming steps in these directions to properly set the auxiliary function.
Volume is poor overall	If you did not install a baffle this is why you should. Sound increases when it bounces. Try adding a baffle to the speaker and make sure it is securely adhered to where it is mounted. You may want to drill some holes under the speaker to allow the sound to escape
The horn is the only function that works, no other commands	The program/run switch is in program. Press ENG + 1 + Set. If the horn blows, it is in program, slide it back to run.

Steam chuffing is erratic, even at a crawl

The power and ground wires are reverse in the PWR harness. Simply reverse the wires and the problem will go away.

If you encounter problems other than what is listed here, please contact TASTudios at (330) 533-7181 Mon-Fri 10a-6p EST for technical assistance.

Programming Your Locomotive

You may program your locomotive any ID number from 1 to 99. You can also program your SAW board to run one of a couple different types of auxiliary outputs such as smoke units, strobe lights, etc. To program a locomotive you must slide the program/run switch to the program position and set the engine on the track with the power on. Using the Cab-1 remote press the following keys;

ENG + ## (your one or two digit ID number) + SET
(the whistle/horn will blow).

To set up the auxiliary function press

ENG + ## (whichever number you just programmed) + AUX1 + Auxiliary Code. (see the chart below).
(The whistle/horn will blow again.)

Function	Auxiliary Code
Smoke on/off (constant 12 VAC output)	8
Strobe/Mars Light (12 VAC pulsed 1 second on, 1 second off, 1 second on, etc.)	5
Smoke unit on when running, off when idling	4

Slide the program/run switch back to run and you're all set!

We hope you enjoyed your installation and we're certain your SAW board will afford you with many years of command controlled enjoyment. Please visit our website at www.tastudios.com for a complete listing of our other exciting command control products and constant voltage lighting upgrades. We hope that you will remember us for other locomotive upgrades into the future. Thank you again.

Standard Command Control Functions from a Cab-1 remote

The following keys will yield the following results;

- HORN/WHIST** The horn or whistle will blow as long as the key is held down.
- BELL** The bell will turn on with the press of the key. Press the key again to turn the bell off.
- DIR** This changes the direction of the locomotive. The direction the engine is going to move in can be determined by which headlight is illuminated.
- BOOST** Pressing and holding this key will make the engine

accelerate until the key is released. Once the key is released the engine will return to the speed it was at when the key was pressed. Great for “boost” uphill.

BRAKE	Pressing and holding this key will make the engine slow down and eventually stop. It will also activate the squealing brake sounds. Once the key is released the engine will return to it’s original speed.
F Coupler	Pressing this key will fire the front Electronic Coil Coupler and activate the coupler firing sound.
R Coupler	Pressing this key will fire the rear Electronic Coil Coupler and activate the coupler firing sound.
AUX 2	Pressing this key once will turn the headlights off. Pressing it again will turn the lights on again.
AUX 1	Pressing this key enables the numeric keypad to activate the following sounds;
AUX 1 + 1	Volume increased (each press of key number 1 will increase the volume one notch. 3 notches total).
AUX 1 + 2	CrewTalk activated (inaudible radio garble).
AUX 1 + 3	Diesel sounds; Engine RPM ramp up. Steam sounds; Air release (air pop off) Start up sounds, used to start sounds up after going Through shut down sound sequence.
AUX 1 + 4	Volume decreased (each press of key number 4 will decrease the volume one notch, 3 notches total).
AUX 1 + 5	Shut Down; activates engine shut down sounds, sounds will turn off. (diesels need to be in lowest RPM cycle (idle)).
AUX 1 + 6	Diesel sounds; engine RPM ramp down. Steam sounds; steam blowdown.
AUX 1 + 7	TowerCom; activates tower communication to engineer (audible).
AUX 1 + 8	Auxiliary output OFF (could be smoke unit, strobe light, MARS light, cab light, etc.).
AUX 1 + 9	Auxiliary output ON (could be smoke unit, strobe

light, MARS light, cab light, etc.).

AUX 1 + 0

Engine reset; resets engine to neutral position, poised to move in the forward direction, resets engine sounds to idle position. Sets front light on.

